



BRADNAM'S

SLIDING WINDOWS

Elegantly simple, classic design



Sliding Window Range

Are you looking for the ideal windows for your home? Our **sliding window** range is a contemporary take on a traditional favourite. Designed to meet all the requirements of the modern home, including security, strength, reliability and expansive views.

Essential Sliding Windows

If you want maximised views and a sensible but aesthetic take on a popular window design, you'll love our 'Essential' sliding windows. Secure, easy-to-operate and easy on the eyes, Essential sliding windows may be our standard sliding window product, but they're still packed full of features and benefits that are anything but standard.

Signature Sliding Windows

Smooth-gliding, easy-cleaning and secure, our 'Signature' sliding windows are stylish and contemporary. They're safe and practical with mortice locks and vent-locking for secure ventilation. Available in large-size options, they can be installed in various spaces and configurations, making them an ideal window for any home.

Performance Parameters

| | Essential | Signature |
|---|------------|--------------|
| Frame size | 52mm | 67mm / 100mm |
| Maximum window height | 2400mm | 2700mm |
| Maximum window width | 3010mm | 5400mm |
| Maximum panel width | 1500mm | 1350mm |
| Maximum panel weight | 24kg | 100kg |
| Maximum water rating | 600Pa | 600Pa |
| Maximum wind rating | 4500Pa ULS | 6000Pa ULS |
| Maximum glass thickness (single glazed) | 6.76mm | 12.76mm |
| Maximum glass thickness (double glazed) | N/A | 20mm |
| Maximum acoustic rating | Rw30 | Rw35 |
| Maximum bushfire rating | BAL 40 | BAL 40 |
| Lowest U-value (single glazed) | 4.4 | 4.7 |
| Lowest U-value (double glazed) | N/A | 3.0 |

Note: Performance figures are independent of each other and subject to conditions. Contact a Bradnam's Windows & Doors representative to discuss your specific project requirements.

Standard Features

Essential . Signature

- Ideal as a servery window
- Ergonomic and easy-to-use-handle
- Wide openings invite fresh air into your home
- Can be used as a kitchen splashback to bring in more light and ventilation
- Effortless operation with high-performance, adjustable rollers
- Easy-to-clean wide track that can fit most vacuum heads
- High-quality seals provide superior protection against the elements
- Available in a range of lifestyle configurations
- Fully compliant with Australian Standards

+ Premium Features

Signature only

- Save on electricity bills with optional double glazing
- Available in larger sizes
- Mortice lock fitted in the handle for superior security
- Night latch locks the window preventing someone from opening it from the outside without a key
- Built-in 'sill baffle' minimises the amount of dust getting inside the house
- Curtain-friendly design protects window furnishings from damage
- Architectural symmetry with other Bradnam's windows and doors

Optional Upgrades

Essential . Signature

- Wide range of screening solutions are available
- Reduce outside noise by incorporating our Sound Smart™ system
- Keys can be 'keyed alike' with Bradnam's doors for convenience¹
- Windows can be locked slightly open for ventilation using vent locks
- Openings can be restricted for upper storey windows
- Create a Hamptons look with colonial bars
- Suitable for cyclonic regions
- Bushfire rated – certified up to BAL 40

¹ Excludes patio bolts and commercial hinged & pivot doors



Smart Solutions

High Performance Windows and Doors

Essential . Signature

Building in today's environment requires you to satisfy energy efficiency, acoustics, security and bushfire requirements. Bradnam's **Smart Solutions** range is designed to augment all Essential and Signature products to satisfy these needs.

Some of the possible benefits

- Cooler in Summer
- Warmer in Winter
- Enhanced UV protection
- Reduce outside noise
- Save on energy bills
- Added security

Performance comes from **more** than just glass

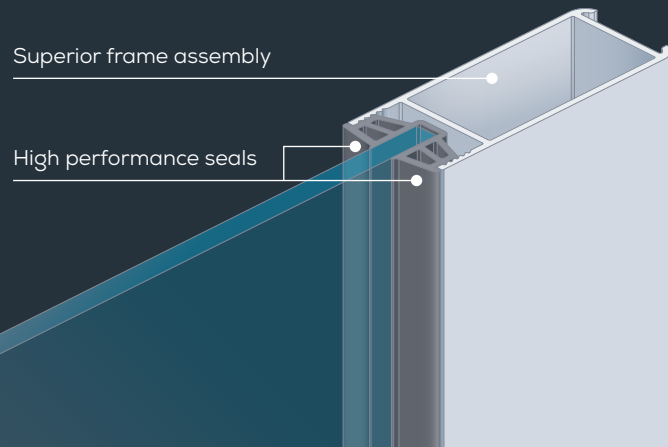

As the market leader in Australia for aluminium and glass building products, Bradham's have developed its range of **Smart Solutions** to meet all high performance requirements.

+ Premium Smart Solution

Double Glazed*

Year-round Comfort

- Acts as extra insulation by limiting the flow of hot or cold air in and out of your home
- Helps maintain comfortable temperatures inside across all seasons

Energy Reduction

- Reduce reliance on air conditioning and heaters – lowering electricity bills
- Consume less energy for a smaller carbon footprint

Noise Reduction

- Minimise outside noise – creating a quiet haven inside your home

Safety

- Extra strong resistance to unwanted attacks by intruders

* Not available in Essential

Climate Control Solutions

Solar Comfort™

Year-round Comfort

- Designed to reflect heat away in summer and keep heat inside during winter
- Enjoy the ideal temperature in your home all year round – cooler in summer, warmer in winter

Energy Reduction

- Keep power bills down by reducing the need for additional heating and cooling
- Help save the environment by consuming less energy

Solar Block™

Cooler in Summer

- Minimise the flow of heat into your home – enjoy summer without feeling the heat
- Acts like a pair of sunglasses for your home, reducing glare by up to 78%

Energy Reduction

- Save on electricity bills by reducing the need for air conditioners
- Minimise your carbon footprint by consuming less energy

Specialty Solutions

Safety*

Safety

- Effective, affordable barrier against forced entry
- Enjoy peace of mind knowing that your home has extra protection

Sound Smart™

Noise Reduction

- Reduce unwanted external noise – nearby traffic or noisy neighbours,

FlameShield™

Superior Bushfire Protection

- Meets Australian Standard AS3959:2009, which is aimed to reduce the risk of loss of life and property in bushfire prone areas

SLIDING WINDOWS

Essential . Signature



Hardware

The hardware displayed on this page are a guide only. Bradnam's recommend the viewing of an actual hardware product prior to order.

| Black Matt | Black Gloss | White | Ultra Silver |
|------------|-------------|-------|--------------|
|------------|-------------|-------|--------------|

| | | | |
|-----------|---|---|---|
| ESSENTIAL | • | • | • |
| SIGNATURE | | • | • |

ESSENTIAL

SIGNATURE

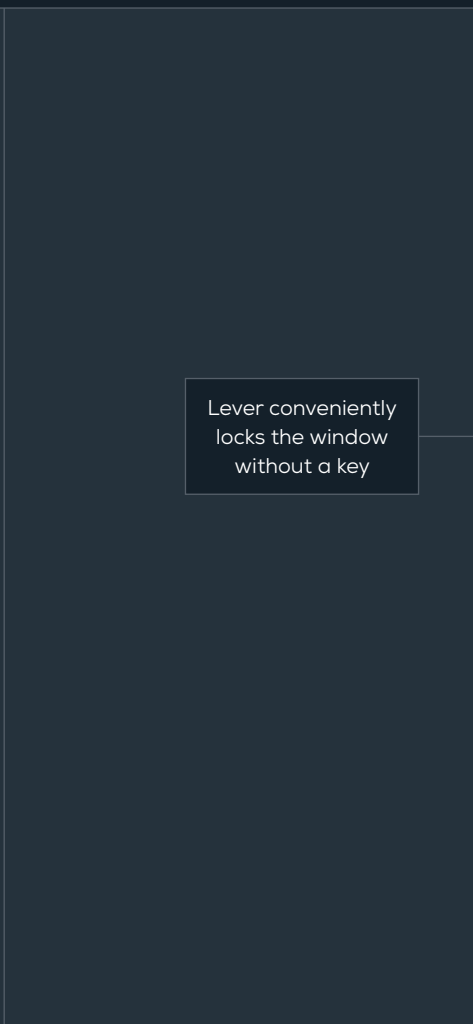

Lever conveniently locks the window without a key



Mortice lock for improved security



For more information call Bradnam's on
1300 WINDOWS 1300 946369
or visit bradnams.com.au



/bradnams



/bradnamswindowsdoors



/company/bradnams-windows-and-doors



/bradnamswindowsanddoors

WINDOWS & DOORS

INSECT & SECURITY SCREENS

SHOWER SCREENS

MIRRORS & WARDROBES

GLASS SPLASHBACKS & SHELVING



Australian Owned & Made

Bradnam's products are proudly made in Australia and designed specifically to meet all Australian conditions.

Product availability, pricing, features, options, sizes, configurations and performance are subject to regional variations, design requirements and building codes.

Images are for illustration purposes only and may not accurately represent the product. Bradnam's Windows & Doors reserves the right to change, alter or delete any aspect of this product without notice.

We recommend visiting a Bradnam's showroom before ordering to view colour swatches, glass samples and actual products.



Bradnam's
windows & doors

AV Jennings

Bradnam's Windows and Doors . QBCC Act lic 58885
© Bradnam's Windows and Doors . v4 Apr 2022